

L SHAPE OPTION 2
 CHAIN LENGTH:
 26400mm
 NUMBER OF PITCHES: 44
 Min TIME TAKEN TO
 COMPLETE LAP: 80 secs

SECTIONS REQ:
 1490 (Motor)
 2x Tensioning units
 1x 800mm
 1x 2674mm
 2x 2285mm
 1x 600mm
 1x 650mm
 1x 1669mm
 1x 1631mm
 2x 1271mm
 6x 90deg Bends

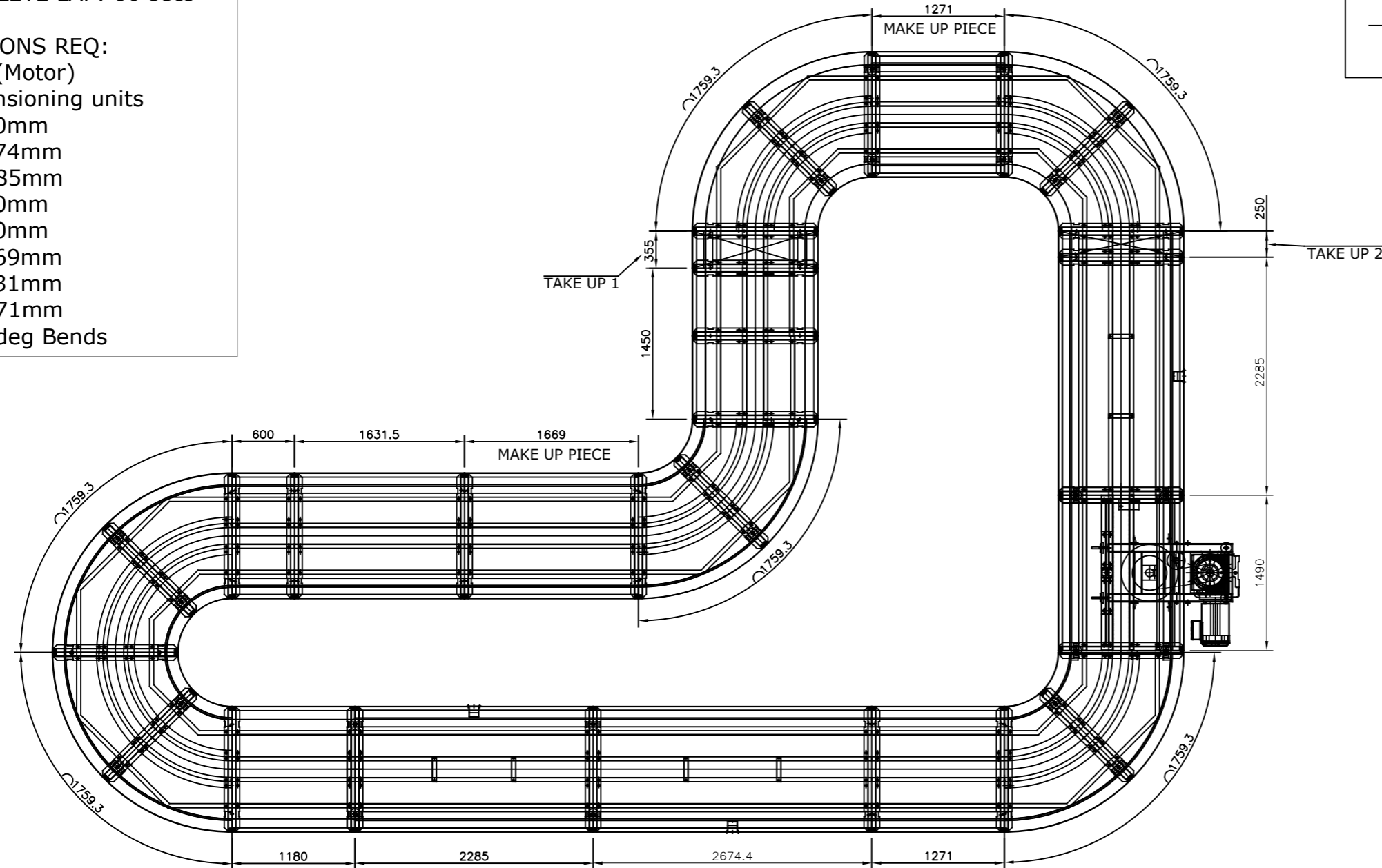
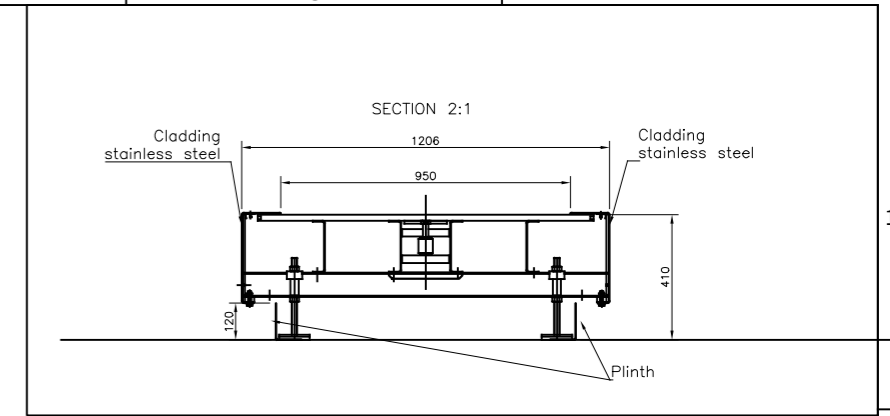

REV	DATE	DMN	DESCRIPTION

THIS DRAWING IS CONFIDENTIAL AND IS THE PROPERTY OF -
CANNING CONVEYOR Co. LTD.
 AND MUST NOT BE REPRODUCED EITHER WHOLLY OR PARTLY WITHOUT THEIR WRITTEN PERMISSION. ALL RIGHTS IN RESPECT OF PATENTS, DESIGN, AND COPYRIGHTS ARE RESERVED.

REMOVE ALL BURRS AND SHARP EDGES STAMP, ENGRAVE OR ETCH WHERE INDICATED THIS (WHERE POSSIBLE 10mm MIN) (SEE NOTE 1) / MANUFACTURE UNLESS OTHERWISE STATED
 UNLESS OTHERWISE STATED THE FOLLOWING BRITISH STANDARDS TO BE WORKED TO -
 DRAWING OFFICE PRACTICE B.S. 308 WELDING SYMBOLS B.S. 499

DO NOT SCALE IF IN DOUBT ASK
 ALL DIMENSIONS ARE IN MILLIMETRES UNLESS OTHERWISE STATED
 TOLERANCES TO BE AS BELOW UNLESS OTHERWISE STATED
 MACHINING: LIP TO 100 ±0.15, 100 TO 300 ±0.40, 300 TO 1000 ±0.60
 FABRICATION PLATE & STRUCTURAL WORK: LIP TO 300 ±1, 300 TO 1000 ±2, 1000 & ABOVE ±3

ASSOCIATED DRAWINGS
 PROJECTION ~

APPROVED: DATE
 CHECKED: DATE
 DRAWN: SF
 DATE 18/09/17

SCALE: NTS

CANNING CONVEYOR Co. LTD.
 Sandy Lane Industrial Estate, Workop, Notts. S80 1TN.
 Telephone: Workop (01900) 486166
 Telex: 547308
 Fax: (01900) 500638

CLIENT CANNING CONVEYOR LTD
 TITLE CAROUSEL SYSTEM
 Option 2b - L SHAPE

DRG. N° **LAYOUT FLIPPED** REV 0